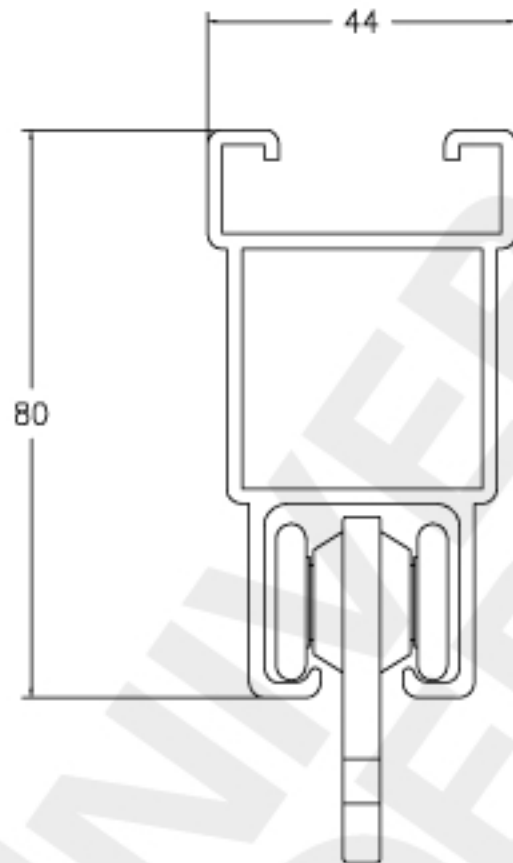

TRACK AND TROLLEY SECTION (approx full size)

DESCRIPTION	MATERIAL	WEIGHT
TRACK	ALUMINIUM	1.397 Kg/m
CRICKET MESH 50mm	NYLON	0.083 Kg/sqm
GOLF MESH 22mm	NYLON	0.150 Kg/sqm
ARCHERY MESH (micro)	NYLON	0.400 Kg/sqm
CURTAINING	COTTON	0.390 Kg/sqm
SIGHT SCREENING	COTTON	0.490 Kg/sqm

Standard colours of nets and curtains are either Green or White. Special colours are available at extra cost. Trackway is self colour as standard. Powder coating is available at extra cost.

Nets can be flame retardant treated at extra cost.

TITLE TRACK AND NET GENERAL
DETAIL

INFO SHEET No.

21

DATE

26/10/05

ISSUE

D

DRAWN

RR

SCALE

N.T.S.

Typical arrangement of trackway installation where track runs at 90° to roof trusses. Intermediate fixings would normally be made by clamping or bolting to purlins.

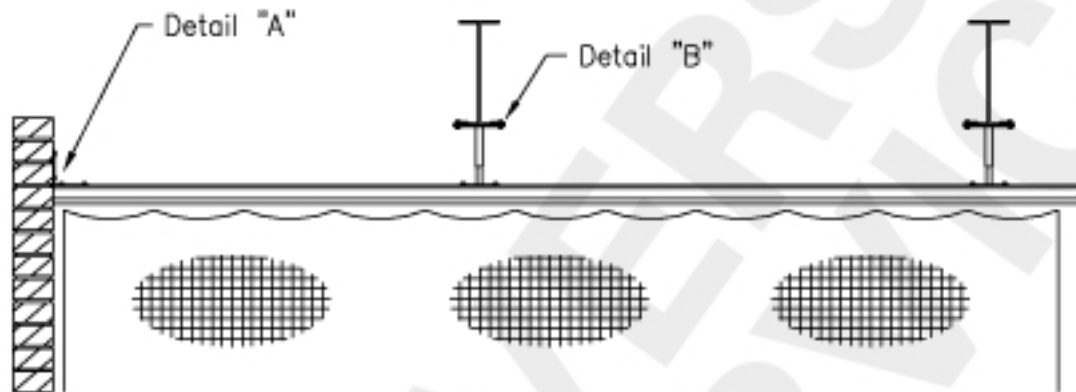

Detail "A"

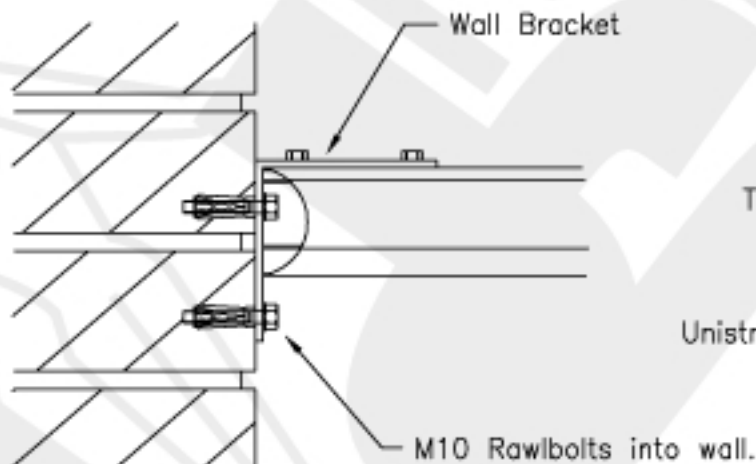

Detail "B"

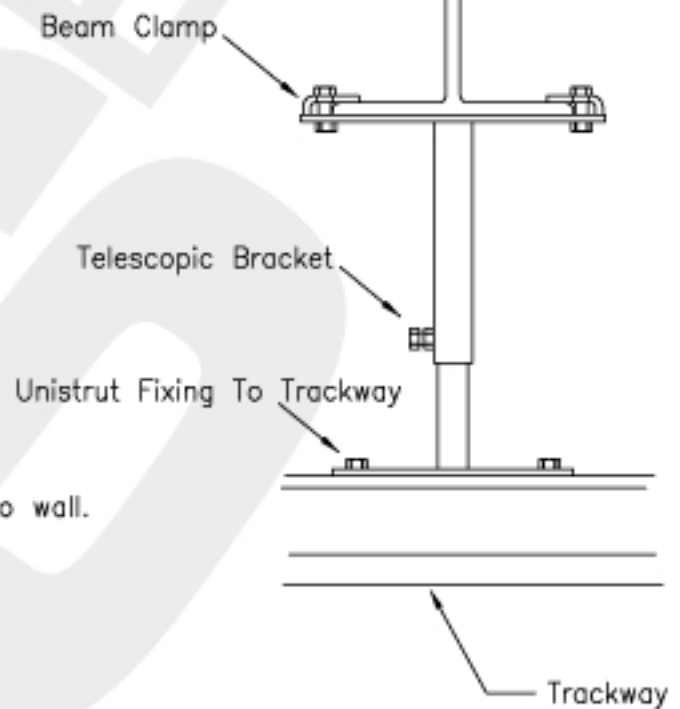

TITLE TYPICAL TRACKWAY FIXING
DETAIL No. 1

INFO SHEET No.

22

DATE

26/10/05

ISSUE

C

DRAWN

RR

SCALE

N.T.S.

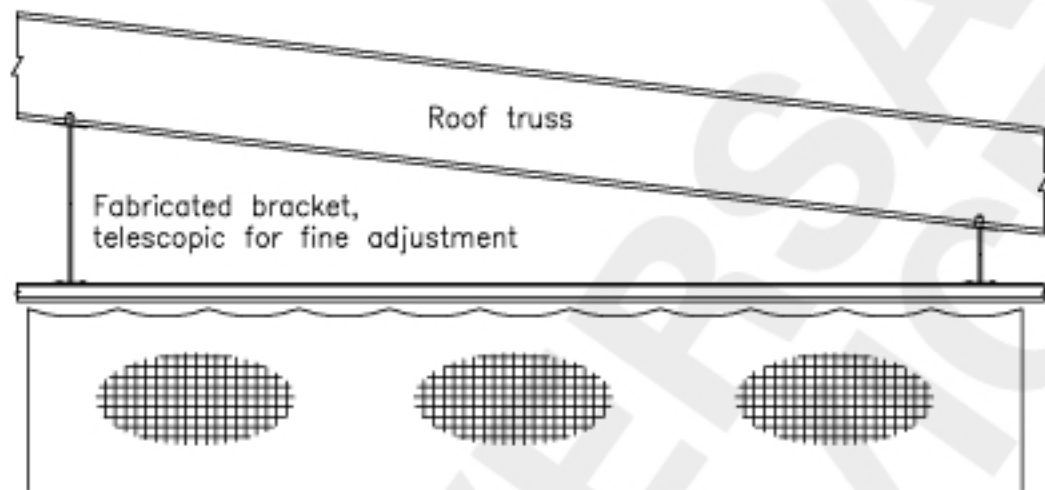

Typical arrangement where track runs directly beneath a cambered roof truss

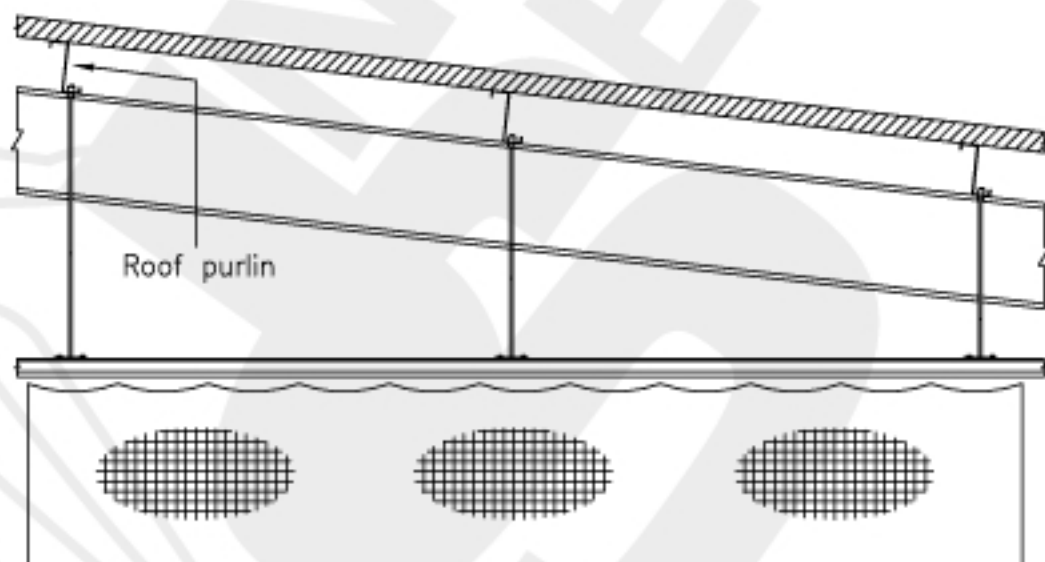

Typical arrangement of trackway installation where track runs parallel to, but inbetween roof trusses

TITLE TYPICAL TRACKWAY FIXING
DETAIL No. 2

INFO SHEET No.

23

DATE

28/7/03

ISSUE

C

DRAWN

KT

SCALE

N.T.S.